

Water Quality Monitoring System

S. Beula

Assistant Professor, Department of ECE, Dr. Sivanthi Aditanar College of Engineering, Tamil Nadu, India

Abstract: Water is an important natural resource and is required in our daily life. The proposed system aims to design a wireless acquisition system which is the basic building block of the water quality monitoring system. This explains the work carried out to design the embedded wireless monitoring system that can measure the turbidity, temperature and pH of the water remotely. The system is built using the Arduino microcontroller. The system consists of two sections, namely, Transmitter section, that collects the temperature, pH and turbidity readings from remote place and the Receiver section, that collects transmitted readings using the GSM wireless communication protocol. The results are classified into three classes using the different Temperature, pH and Turbidity levels to get a water quality index. The results are displayed on the LCD as well as on mobile over different time periods.

Keywords: Arduino, PH Sensor, Turbidity Sensor, Temperature sensor, GSM Modem.

I. INTRODUCTION

In the current era, we are moving towards making our cities as the smart cities, due to the lot of technological research and inventions over the decades. So the current era is said to be era of inventions, era of development, era of globalization and the era of smartness etc. But the counter side of the same is that the current era is era of the pollution, global warming, insecurity and miserable health factors. The main causes for this are the ignorance of people & government sector and the deficient water quality monitoring system, which results in serious health issues. The motivation behind the proposed system was to design a wireless system to monitor water quality in a simplest and cost effective manner. This system can analyze some important and harmful factors of water to take preventive actions for water quality maintenance.

II. RELATED WORK

In current world water sources are polluted through industries, etc.,. Industry chemicals contaminate the water resources. This H₂O auto check meter protect our water resources. If any one polluted then it will send a alert to main server so we can find the culprit and we can compliant them using legal team.

To check and defence the water using the design of wireless system to monitor water quality in a simplest and cost effective manner used. This system can analyze some important and harmful factors of water to take preventive actions for water quality maintenance. The pH sensor and turbidity sensor are used to collect the pH and turbidity level of the water . With the use of GSM technology, we can get the data from the remote areas. The sensors have the analog

output, hence they are interfaced to analog input of the Arduino microcontroller and the data are transferred through the GSM. The real time data, at the receiver section, is displayed on the LCD as well as on Mobile. The H₂O auto check is check the water quality. It check the water PH level and It will check turbidity and the water quality. If any changes from the water. The water is non drinkable then it will send a SMS alert to mobile or system

III. BLOCK DIAGRAM

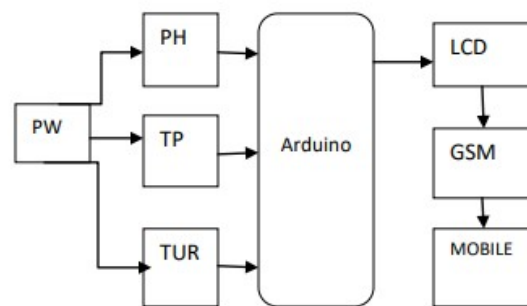

Fig1: Block diagram of H₂O Auto check

According to block diagram the H₂O auto check consist of Arduino Board,(16 * 2) LCD display. The 2 in one Temperature and PH sensor, The Turbidity Sensor, A GSM shield. First the sensor sense the level in the water using the devices then it will send the analog values to the arduino. Then Arduino will process the input by using the program. Then it display the values in the LCD and send the alerter via SMS using GSM modem.

A. Arduino



Fig2: diagram of arduino

Arduino UNO is a microcontroller board based on the ATmega328 (datasheet). It has 14 digital input/output pins (of which 6 can be used as PWM outputs), 6 analog inputs, a 16 MHz ceramic resonator, a USB connection, a power jack, an ICSP header, and a reset button. The Arduino UNO can be

powered using two the USB connection and external power supply.

pH sensor

The pH probe SEN0161 is used as the pH sensor with the BNC connector. When dipped into the solution, it

provides the output voltage in millivolts with respect to the hydrogen ion concentrations in the solution. The output voltage range is from -414mV to +414mV with the operating temperature range of 0-60 degree Celsius. It has the accuracy of 0.01ph. The output voltage is positive for the acidic solution and negative for the alkaline solution. For neutral solution it gives zero output. The output pH range for SEN0161 is from 0 to 14. The pH sensor v1.1 is used as the signal amplification circuit to boost the output from mV to volts.



Figure.4.PH sensor

Turbidity sensor

Turbidity sensor module



Figure.4.Turbidity sensor

As shown in Figure 3.5.the SEN0189 module is used as the turbidity sensor. The SEN0189 module measures the turbidity (amount of suspended particles) of the water in river, lakes etc. It has operating voltage of 5V and operating current of 40mA. It has analog output from 0 to 4.5V with the response time less than 500mS. Also it has operating temperature range from 5 to 90 degree Celsius.

Temperature Sensor:



Figure.5.Temperature sensor

This used to measure the water temperature. It is a single wire digital output sensor. It has output temperature range from -55 to +100 degree Celsius. It has +/-5 degree Celsius accuracy from -10 to +85 degree Celsius. It converts temperature in 750mS. The purpose of using this sensor is to measure the water temperature with respect to surrounding temperature.

GSM Module:



Figure.6.GSM modem

GSM is a mobile communication modem; it stands for global system for mobile communication (GSM). The idea of GSM was developed at Bell Laboratories in 1970. It is widely used mobile communication system in the world. GSM is an open and digital cellular technology used for transmitting mobile voice and data services operates at the 850MHz, 900MHz, 1800MHz and 1900MHz frequency bands.

IV. RESULTS AND ANALYSIS

While the water is normal the pH level well be normal. and it has been shown in Figure7.

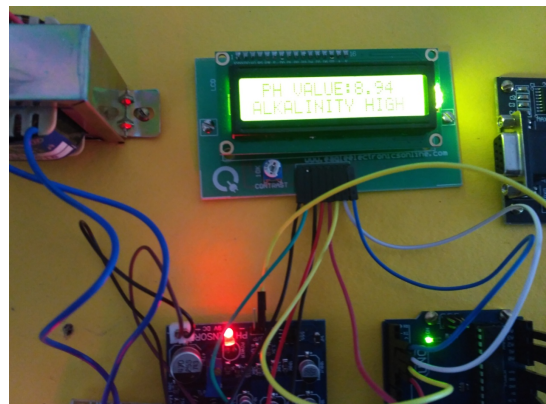

Figure.7. Added alkalinity level of water output

When the substance added in water the water quantity has been changed and it has been found as alkalinity and it has shown in figure.8

V. CONCLUSION

The system provides the wireless water quality measuring tool with remote data collection. The data is collected at the receiver section and depending on the pH level and turbidity level, the data are classified and water quality is decided.. In Smart Cities, the big housing societies provide the direct drinking water, which is stored in the tank at the top of building. The system can predict the drinkable water quality and displays the readings on the LCD, which can be mounted inside the individual home. Also it can be implemented in the chemical plants, where the sewage water is driven into the Rivers and lakes. We can predetermine the water quality, before driving it into Rivers and lakes, to avoid the water pollution

REFERENCES

- [1]. Kulkarni Amruta M, Turkane Satish M, “Solar Powered Water Quality Monitoring System Using Wireless Sensor Network”, IEEE International Multi-Conference on Automation, Computing, Communication, Control and Compressed Sensing (iMac 4s), 2013.
- [2]. Ayushi S Jaiswal, Vaidehi Baporikar, “Embedded Wireless Data Acquisition System For Unmanned Vehicle In Underwater Environment”, IEEE , 2015, in press.
- [3]. Saaid, M.F., Sanuddin, A.,M.S.A.I.M Yasin “Automated pH Controller System For Hydroponic Cultivation”, IEEE Symposium on Computer Applications and Industriail Electronics, 2015.
- [4]. F Ntambi, CP Kruger, BJ Silva, GP Hancke, “Design Of a Water Management System”, IEEE, 2015, in press.
- [5]. “pH in Drinking Water”, Originally Published in Guidelines for Drinking-Water Quality, 2nd ed. Vol. 2, Health Criteria and Other Supporting Information, World Health Organization, Geneva, 1996.
- [6]. “Turbidity in Drinking Water”, EPA Drinking Water Advice Note, Note no-5, Version 1, 2 Nov 2009.