

Development of Bjt-Fet Circuit Card and Small Signal Analysis of Bjt Circuit Card

Anthony C. Cabrillas

College of Industrial Technology

DOI: <https://doi.org/10.51244/IJRSI.2026.1303000035>

Received: 06 March 2026; Accepted: 11 March 2026; Published: 26 March 2026

ABSTRACT

A PCB-based BJT-FET Circuit Card and Small Signal Analysis of BJT Circuit Card were designed, developed, and evaluated in this study consisting of three instructional modules: Module 7 (BJT Circuit Card/BC Card), Module 8 (Small Signal Analysis of BJT Circuit Card/SABC Card), and Module 9 (FET Circuits Card/FC card). Pertaining to Objective 2, the module provides a BJT Circuit Card using an integrated PCB design that clearly identifies network paths for biasing signals, hardware test points and utilities, as well as test point access directly with respect to schematic alignment more easily translatable for students. To address Objective 2, validation of the developed PCB modules was achieved by comparing the electrical performance against design specifications and criteria. The results of DC biasing confirmed stable operating points suitable for instructing a transistor at the input (CE bias values: $V_B = 0.69$ V, $V_C = 5.92$ Volt near mid-supply), tracking behavior on common collector level crossing ($V_E = 5.95$ Volt, $V_B = 6.66$ Volt), and common base stability ($V_C = 6.05$ Volt). At this point, I verified expected behavior dependent on configuration through small-signal testing where measured gains were $A_v = -39.0$ Common Emitter with 180° phase inversion (in-phase follower), $A_v = 0.90$ for Common Collector (follower behavior again) and $A_v = 29.5$ for Common Base (follower in-phase). Device configurations of FET module, CS, CD and CG measurements were also stable ($V_G \approx 2.48$ V; $V_S \approx 1.44-2.32$ V; $V_D \approx 5.85-5.90$ mV) thus confirming that reliable amplification and follower properties performance could be demonstrated with the module developed here. As per Objective 3, usability in terms of functionality was assessed through a Technology Acceptance Model (TAM)-based survey for 35 students who displayed very high acceptance across the constructs (PU = 4.62, PEOU = 4.55, BI = 4.58, US = 4.60; mean overall = 4.59). The instrument was good-to-excellent reliability (Cronbach's $\alpha = 0.88-0.93$) and one-way ANOVA showed no significant differences among construct means ($F = 1.10$, $p = 0.35$) with a small effect size ($\eta^2 = 0.024$), confirming balanced uniform usability perceptions. Explaining, data in comparison to other considerations, the performance and design negotiation result are considered very permissible for the long laboratory aggregation with sector able skills training of all devised circuit cards.

INTRODUCTION

Transistor circuits represent the heart in making function blocks of essential operation regions for signal amplification, switching, regulation and conditioning concerning electronic devotions such as communication channels (Bluetooth), instrumentation operational systems (sensors), process automation devices attached to industry set-up and embedded sequencing electronic platforms. For example, a comprehensive understanding of how transistors work (bipolar junction transistor [BJT] biasing and small-signal amplifier analysis; field-effect transistor (FET) circuit behavior) is a necessary competency in electronics engineering-education-and-technology. These competencies have been applied widely across various manufacturing and service settings in the execution of troubleshooting, equipment maintenance, circuit prototyping and quality assurance activities. And as fundamental as that is, one of the historical issues with introductory education has been that students learn theory and practice on the transistor itself but have little understanding of measurement fundamentals and reading/circuit diagnostics in practices common to many lab or industrial environments.

The problem arises, to a large degree, from the ways we most commonly teach transistors in electronics labs.

In many teaching environments, learning activities are based on simulating circuits or generic trainer boards that obfuscate internal circuit structures and measurement paths. Simulation tools underpin the process of understanding a concept, however, such tools do not allow learners to systematically check their circuits behaviours by touch. As a result students struggle with finding DC operating points, tracing signal flow, identifying biasing network conditions and interpreting oscilloscope traces under real world conditions. The theoretical concept and the practical side diverge quite a bit in small-signal amplifiers, though, as one must rely on biasing and waveform interpretation to characterize gain properties and phase relationships, and how they affect transistor operation in their respective quadrants.

On an industry-level overview, expectations for entry-level electronics technician and technologist were practical analyzation skill sets over theoretical knowledge. In industrial work environments, personnel must interpret circuit diagrams, validate DC bias conditions within circuits, identify faulty components locations in the bias networks and perform signal measurements with oscilloscopes and multimeters. In all of these roles, structured measurement protocols as well as the ability to connect theoretical transistor models with on-chip circuit characterization are required. If educational experiences are not designed to mirror these processes of diagnosis and verification, students emerging from any curriculum may struggle with the transition from academia into practice.

In light of these instructional and industry-aligned challenges, this work details the development of a series of modular printed circuit board (PCB) teaching platforms termed “BJT–FET Circuit Card and Small Signal Analysis of BJT Circuit Card”. The part of the course consists dedicated to instruction in 3 instructional modules: Module 7: BJT Circuit Card (BC Card), Module 8: Small Signal Analysis of BJT Circuit Card (SABC Card) and Module 9: FET Circuits Card (FC Card). For this reason, module construction was especially concerned with instructional transparency and practical testability, which is manifested as labelled circuit areas within the designs and appropriately accessible measurement nodes along with standardized test-points provided. In this design process, students can directly observe and measure key transistor characteristics like BJT nodes voltages (V_B , V_E , V_C), small signal input-output waveforms (V_{in} , V_{out}), voltage gain curves (A_v) and FET terminal nodes V_G , V_S and V_D . These measurement capabilities complement diagnostic tests commonly performed in electronics servicing, manufacturing verification and instrumentation applications.

The analysis was aimed at two primary goals: to validate the electrical performance of the fabricated circuit cards and to evaluate their educational effectiveness. All modules underwent electrical testing to validate the operating specifications (stable DC biasing conditions for each transistor, repeatable small-signal amplification characteristics, etc.) suitable for differing topologies. A confirmation of their active-region transistor operation with configuration-dependent behavior in the common-emitter (gain and signal inversion) or common-collector (voltage following) configuration; stable operating conditions for FET-based circuits that could be used for amplification and follower applications.

In addition to performance validation, the study investigated usability and acceptance of developed modules by student users according to Technology Acceptance Model (TAM) framework. Some of the constructs in particular are perceived usefulness, perceived ease of use, engagement and appropriateness for integration in electronics laboratory instructions. Indeed, the constructs in this study had high reliability indices and respondents ranked them uniformly positive resulting to strong levels of acceptance. These results reflect the instructional and operational goals for which modules under development could be designed to fit and incorporated into lab instructions, technical trainings and skill-based learning programs.

This research is a valuable contribution to the development of hands-on learning in the field of analog electronics education. Realizing this bigger picture, the current work proposes an instructional framework proposing modular PCB development along with real-time performance-dictated electrical validation and usability assessment based on established technology acceptance models; thus creating opportunities for efficient competency enhancement in transistor circuit analysis and measurement. Additionally, the manufactured circuit cards aim to provide solutions for institutional priorities around engineering and technology education through a means of providing hands-on educational experiences for practical skill cultivation in line with industry expectations, as well as enhancing laboratory-pivoted instruction. The BC Card, SABC Card and FC Card are primarily intended as practical tools that enable students and novice engineers to apply their theoretical

knowledge on the inspection of transistors in an electronic circuit diagnostic platform, thereby enriching electronics technology education (both theoretically and practically).

Research Objectives

The study defines a separate set of objectives so as to progress both in understanding our electronic circuitry along with its practical applications. Specifically, the research aims to:

1. design and develop a printed circuit board (PCB) BJT Circuit Card modules,
2. evaluate the Functionality and Effectiveness of the developed PCB modules in terms of its design specifications and performance criteria,
3. Assess the performance of circuit cards in terms of their functional usability.

Review of Related Studies and Literatures

Laboratory learning objectives and experiential structure

Engineering education research has identified the instructional laboratory as a unique learning environment in which students synthesize conceptual understanding by using instruments to conduct empirical reasoning and develop professional judgment. Such early models were further advanced by a contribution from Lyle D. Feisel and Albert J. Rosa, who argued that laboratories should not be add-ons to lecture courses but should instead focus on explicitly articulated aims, including development of instrumentation skills, model validation, experiment design, data interpretation and iterative improvement (Feisel & Rosa 2005).

These goals are directly relatable to electronics servicing, and production description domains, where technicians/technologists need to (i) establish the operating conditions and verify them in run time conditions, (ii) measure key nodes, and (iii) reconcile the behavior they measured with what could be expected from their theoretical expectations of operation as part of verification and troubleshooting routines. Mahmoud Abdulwahed and Zoltan K. Nagy also provide a complementary instructional lens by showing how laboratory learning can be constructed around David A. Kolb's experiential learning cycle that connects conceptualizations, experimentations, observations and reflections.

The key to their work is that hands-on measurement becomes educationally powerful only when learners do more than "doing" procedures: They also record systematic outcomes and reflect on the observed results' discrepancy with those expected. This insight is especially salient for analog electronics, where meaningful understanding requires disciplined measurement and interpretive routines, not just symbolic manipulation of equations.

Research on laboratory modalities helps further delineate how measurement-centered design matters. Reviews and comparative studies demonstrate that, in practice, traditional hands-on labs and non-traditional environments (virtual and remote labs) yield similar learning outcomes under many circumstances; however, they further indicate that evaluated learning outcomes are typically biased toward student conceptual understanding and knowledge assessments at the expense of practical measurement skills, troubleshooting capabilities, or performance-testing abilities.

These metrics cause an asymmetry between the outcome of what needs to be learned (theory) and what will be needed in practice (meticulously measured and calculated competency), hence supporting instructional designs which make measurement and verification easy, visible, assessable—particularly where operating points need to be correct in electronics domains requiring a waveform to be as intact as possible for it to mean anything.

Transistor learning in electronics education and the DC–AC reasoning challenge

In transistor instruction, the technical challenge for students is not only in learning device concepts (e.g. current gain, regions of operation), but also aligning DC bias reasoning with small-signal action (gain, inversion, waveform distortion and coupling/bypass elements). Through tasks focusing on amplifier reasoning, a systematic study by Kevin L. Van De Bogart and MacKenzie R. Stetzer investigated student understanding of

BJT circuit behavior that identified persistent difficulties with freshman students' ability to reason correctly about bipolar junction transistor circuits (including the common-emitter amplifier), suggesting that learners may struggle to connect qualitative circuit function with accurate model-based explanations.

In transistor amplifiers with their high bandwidth, the correct small-signal behavior is contingent upon bias setting up a valid operating region for adding small signals, and hence any misconceptions or piecemeal thinking about operating points will tend to propagate directly into misinterpretation of measured gain and phase behavior.

Literature on electronics education research also identifies troubleshooting as a widely valued learning outcome, but not always systematically supported or assessed in practice. In work with interview-based open-ended questions of electronics laboratory instructors, Dimitri R. Dounas-Frazer and Heather J. Lewandowski found that although troubleshooting appears as an important learning outcome to instructors, only approximately half described assessing students' troubleshooting ability directly.

They found that this competence in troubleshooting is not solely conceptual knowledge of circuits; instead, they argue that it requires procedural knowledge and skillful use of laboratory instruments (e.g., oscilloscope and signal sources).

This justifies the pedagogical need for instrumentation tools that offer structured access to measurements and promote systematic observations—particularly in transistor circuits where students are required to verify node voltages, determine the Q- point, and analyze waveforms consistent with device operation and amplifier configuration.

Design rationale for measurement-transparent PCB training platforms

Across the scholarship in engineering-laboratory settings, a key aspect is that learning transfer is enhanced when the laboratory context makes clear what is at stake with regard to verification: learners have to connect instruments to significant entities, get interpretable measurements and then use those measurements to verify models and diagnose faults. The research performance objectives set forth for engineering laboratories explicitly promote instrumentation and modeling validation as one of their goals.

Such end results are enabled through concrete activities in electronics, such as measuring DC nodes to check the operating region of transistors and validating whether expected waveforms behave correctly under small-signal excitation by comparing measured versus predicted gain/phase relationships.

In another way, remote- and technology-mediated laboratory research can take this insight about measurement access one step further. What comparative reviews indicate is that any assessment of different laboratory formats needs to be judged in the light of their educational objectives; for example, if these objectives include developing skills in design or doing practical measurements, then it is important that the laboratory setting promote genuine experimentation and real engagement with instrumentation.

This has implications for transistor education, in that the hardware that is used to teach with should not merely “contain circuits” but expose deliberate circuit structure 7 ways unique learners can trace signal flow, measure important nodes and verify configuration-dependent behavior. This is in accordance with poor measurements findings more focusing to diagnostics where proper ones for purpose, thus types of measurement and conditions on systematic measures are needed appropriately.

Designing PCB modules to be used as trainer examples is justified in established literature when such devices (a) have indicated sections of internal circuits accessible for student interaction, (b) contain common and standardized access test points enabling repeatable circuit measurement, and finally yet most important - (c) help fill an activity that reinforces formative learning relevant to their professional practices.

This design directly operationalizes the core objectives of the laboratory — instrumentation, model validation, and data interpretation — as well as addressing known learning bottlenecks in transistor reasoning by requiring students to negotiate how to coordinate DC bias monitoring concomitantly to AC waveform analysis.

Evidence of usability and acceptance of lab technology integration

Given that innovations in laboratories must be sustained in the face of limited curricular time and resources, the literature on educational technology adoption proposes evaluating not only whether a new laboratory activity or exercise is technically correct, but raised its acceptance among users.

First to develop the Technology Acceptance Model (TAM) — an IS adoption model, via introduction of perceived usefulness and perceived ease of use constructs also conducting EMPIRICAL study that provided validated measurement scales for these constructs.

This assumption has underpinned many assessments of whether users believe the tool will yield superior performance and if they can quickly master using it — both critical for laboratory-devices that must operate reliably despite finite session durations at varying expertise levels.

Studies like these developed and elaborated on this viewpoint. Then they evolved TAM2 by incorporating social influence and cognitive instrumental processes to explain perceived usefulness and intent of usage (Viswanath Venkatesh & Davis, 2000).

Although meta-analytic evidence supports the generalizability of TAM across contexts, data also indicate that relationships in the model vary according to user type and context of use.

Meanwhile, critical studies have reported discrepancies between empirical research and warned that contextual factors may frame acceptance which require careful operationalisation and interpretation of the TAM components within applied educational environments (Ayeh et al., 2013; Cheong & Park, 2005).

Under laboratory conditions, these findings make it possible to use TAM (or TAM-informed instruments) as a means of assessing if instruction tools are not only functionally-bypassed but also practically-useable, pedagogically-loosely-abstract, and worthy of subscription-in-class supervision monitoring from the perspective of their learners.

Gaps addressed and contribution of the Study

Integrating these strands of research reveals convergent support for the direction of Study 4 but also highlights gaps that it is uniquely positioned to fill.

First, engineering laboratory scholarship firmly supports the design of labs around measureable objectives including instrumentation recall, model validation and data interpretation — but electronics instruction often fails to define/operationalize these objectives such that they reliably foster measurement discipline and diagnostic reasoning in transistor circuits.

Second, education research on transistors shows that students continue to face difficulties in reasoning about BJT circuits and the behavior of amplifiers, indicating a concern that traditional teaching methods may fall short by not bridging learners' understanding of how to establish an operating point with small-signal interpretation of linearized circuit behavior.

Third, reviews of laboratory modality indicate that “learning outcomes” are frequently assessed in a way that minimizes performance-focused measurement and troubleshooting skills directly related to diagnostic competence, leading to practical evidence gaps regarding how educational interventions promote industry-relevant diagnostic habits. Finally, though research on TAM offers a seasoned framework for measuring acceptance and adoption, laboratory hardware interventions in analog electronics are not always assessed with an integrated approach that combines (a) the validation of electrical performance with (b) evidence of user acceptance using validated constructs of acceptance. In this literature-supported context, Study 4 complements past data by relating development of modular PCB circuit-card directed learning toward: (i) laboratory objectives championed in engineering education scholarship (instrumentation, model validation, data interpretation), (ii) empirically evidenced requirements in transistor conceptualization and troubleshooting instruction, and (iii) sustainability-pointed appraisal via TAM constructs supporting prolonged instructional adoption.

CONCEPTUAL/ THEORETICAL FRAMEWORK

Operationalizing an integrated Input–Process–Output (IPO) model through the ADDIE instructional development process while being enhanced technological valid and user-centered instructional adoption through Technology Acceptance Model (TAM) evaluation. The integrated framework functioned as a structured pathway through which the three modules of Study 4—Module 7: BJT Circuit Card (BC Card), Module 8: Small Signal Analysis of BJT Circuit Card SABC Card) and Module 9: FET Circuits Card (FC Card)—were established as instruction- and industry-oriented circuit training tools. As inputs, course and competency outcomes were aligned with analog electronics and transistor circuits, appropriate transistor datasheets and operating parameters, component specifications and tolerances to consider during experimentation at hardware level, laboratory safety requirements (non-negotiable items) as well as measurement/equipment constraints. These inputs helped ground the module design in curricular expectations and authentic circuit practice.

The Process element applied the ADDIE steps resulting in defined and cyclic design. The Analysis indicated requirements based on usage for Instruction/Instructions, public network-based biases in industry along with points to test against bias and output measurements leading into a small signal behaviour toward industry. Phase 2: Design[edit] —An application for a BJT and FET was configured as schematics that referenced the required test-points due to our reusable schematic tooling allowing for schema-to-PCB correspondence. The Development steps were followed up with PCB fabrication, assembly, debug and verification of the circuit functionality. As a result, in the Implementation phase the modules were embedded into lab activities and guided measurement tasks to validate DC biasing conditions and assess small-signal waveforms. Finally, the Evaluation phase integrated two supportive assessments: (1) evaluation of functional performance (stability against a bias, gain behaviour and configuration-dependent responses), and (2) usability and acceptance assessment via TAM. Outcomes included fully functional types of unit load and empirical documentation regarding the technical performance with and pedagogical potential observed at the time with respect to card module itself (BC Card, SABC Card, FC Card). The TAM constructs: Perceived Usefulness (PU), Perceived Ease of Use (PEOU), Behavioral Intention (BI) and User Satisfaction (US)—provided the evaluative dimensions for functional usability, acceptance and readiness for sustained instructional integration and training deployment.

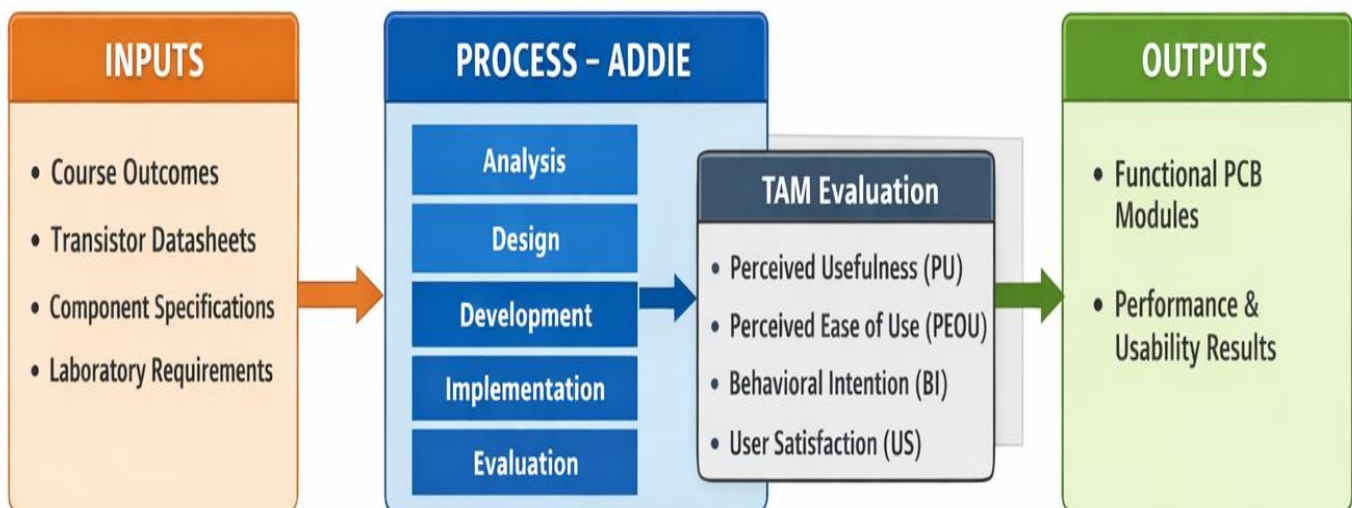

Figure 1: IPO Model Implementing ADDIE-TAM Hybrid

MATERIALS AND METHODS

Research design and methodological framework

Study Four employed a developmental–descriptive research design to (a) develop PCB-based instructional circuit cards, and (b) to report on their manifested electrical performance and user acceptance post-implementation in guided laboratory activities. This approach is consistent with instructional technology

traditions in the domain of developmental research, where the concern of researchers is to systematically design, develop and evaluate (assess) instructional products/tools while providing evidence — relevant to a specific context — that the product will succeed on performance & usability measures. In the developmental research typology, this project aligns most closely with Type 1 developmental research (product/tool development), as it focuses on constructing an instructional product (the circuit cards) and testing and evaluating it rather than a new larger-scale proposed or validated instructional design model. To organize development work, the study adapted an instructional design framework (ADDIE) and combined it with standard electronics engineering prototyping and validation practices. ADDIE, which is usually described as the process of Analyze, Design, Develop, Implement, Evaluate in succession (and sometimes again), is a very popular organizing framework for systematic instructional development and iterations.

Participants and sampling strategy

In the usability and acceptance phase, the 35 respondents were the same student users who used the developed modules in guided laboratory activities and completed a Technology Acceptance Model (TAM)-based questionnaire. This is referred to as an intact-group, non-probability (convenience) sample and reflects many classroom and laboratory-based product evaluations in which only learners with firsthand experience of the instructional tool being investigated may take part. This sampling approach aligns with developmental product/tool research, in which the primary function is to determine if the prototype performs as it should in its target instructional context and if users find it usable and beneficial.

Taking part was voluntary, and responses were treated as confidential and used only to inform research and improve teaching practice (in accordance with standard ethical expectations for non-invasive educational evaluation).

Module scope and development procedure

Modules developed

Development output: Three PC-based instructional cards with a known measurement configuration to achieve transparency for finding and troubleshooting circuit nodes (this is controlled EMC-based output in a distributed fashion) : Module 7 — BJT Circuit Card (BC Card)—for biasing for the BJT, or configuring behavior using known accessible DC test points (base, emitter, collector nodes).

Module 8: Small Signal Analysis of BJT Circuit Card (SABC Card)—(V_{in} – V_{out} measurement, gain computation and phase behavior across BJT amplifier configurations for small-signal amplifier experiments. Module 9: FET Circuits Card (FC card) to study the behavior of FET utilizing available gate-source-drain test points and output nodes for measurements. This modular “product + evaluation” system aligns with product/tool developmental research, wherein the artifact is the subject analysis unit and the technical phase validation constitutes intrinsic evidence. A Generic Addie-Ad, Engineering And Instructional Development Workflow ADDIE The product and process heavy lifting was based on ADDIE as an umbrella to a Electronics Technology workflow: Analysis: Future facing- instructional, industry demands coupled with some realizable gaps in bias check, wave form review interleaved with measurement based (hunting routines).

Design Draft: Logical signal flow, respect for safety protocols, clear defined labels and standard test point locations on copy and PCB layouts. Design: PCB modules prototyping and debug (Continuity tests, components verification, wiring/layout issue solving). What It Is Used For: Fold into structured lab work on DC node measurements, waveform observation, gain calculations and comparisons of configurations. Actually, you could parallel my two evaluation paths as no. (a) electrical performance / testing and no. (b) TAM based third party usability/acceptance.

Branch’s treatment also emphasizes that ADDIE serves as, at least in part, an overall organizing schema even for instructional systems development (ISD) work in which recursive refinement across phases to gather cyclical information—guided by a graphic of instruction—is sought rather than the strictly linear and one-pass execution consistent with hardware prototyping and debugging cycles.

Data collection procedures

Electrical performance testing protocol

Each of these modules provided appropriate operating conditions and configuration dependent behavior, confirmed by results from empirical measurements in electrical performance testing. Standard electronics laboratory instrumentation (i.e. digital multimeter, oscilloscope and a signal source/function generator) was used for measurement. The protocol included: DC biasing verification (BC Card) BJT Node Voltages were observed in predetermined test sites—base, emitter and collector—to confirm if the bias condition of each solution was stable and followed the desired operating area under accomplish configuration of the module. The idea behind the design was that accessibility to nodes lends itself to systematic verification and interpretation of operating points (i.e measurement-based validation rather than simply inference). This focus on assessing an instructional product's functional performance also serves as a core expectation for Type 1 developmental research.

Small-signal testing (SABC Card)

The input was controlled AC and the output was measured. A_v was determined as a function of configuration (i.e. inverting vs non-inverting), and phase behavior (e.g. inversion vs non-inversion) was assessed via oscilloscope traces while users noted waveform characteristics.

The statement of measured V_{in} – V_{out} behavior as evidence speaks to the developmental research requisite that, at least for products, their claims be supported through systematic, empirical performance evaluation.

FET functional testing (FC Card)

FET terminal voltages (V_G , V_S , V_D) were recorded under operating conditions to ascertain stability and verify intended functional behavior and facilitate comparisons across FET configurations (common-source, common-drain, common-gate), as pertinent for module design.

Electrical data collection across all modules had a performance documentation logic: “measure → compare against specification/expectation → record outcome,” yielding traceable evidence that the developed instructional tool is in line with its design targets.

Usability and acceptance data collection

After guided laboratory activities in which they used the modules, students completed a TAM-based questionnaire to determine their perceived acceptance and usability of the circuit cards.

TAM largely articulates acceptance in terms of PU and PEOU that have independent effects on intention to use and usage behavior; it gives Davis the mapping of imputed scales that measure these constructs in applied contexts.

This study employed four constructs embraced by TAM and usual extension of the most common contexts for educational technology evaluation:

Perceived Usefulness (PU)

Perceived Ease of Use (PEOU)

Behavioral Intention (BI)

User Satisfaction (US)

Emphasizing that the path from perceptions regarding usefulness to behavioral intention (i.e., such as TI) can be constructed based on considerations of social influence and cognitive instrumental processes, TAM extensions (e.g., TAM2) lend support for the general argument even beyond technical correctness for estimating acceptance.

Tools and instruments

Engineering and laboratory measurement tools

Standard electronics fabrication and measurement resources appropriate for PCB prototyping and amplifier testing were used in the study: PCB fabrication and assembly materials included FR-4 (PCB substrate), BJTs, FETs, resistors, capacitors (discrete components) terminal connectors test points with a dedicated label. Measurement instruments: The DC node voltage was measured using a digital multimeter (DMM); waveforms were captured, and phase/gain were observed. Test Process and Equipment: Signal source/function generator to provide small-signal excitation for amplifier tests. This studies essential functional claims (stable biasing, measurable amplification/follower behavior, interpretability of waveforms) are operationalized into these instruments; this work is in line with what is typically expected of exploratory research in product/tool development [1], namely that evaluation evidence should directly map to the product's defined intended contribution in functional terms.

Questionnaire instrument for acceptance and usability

Acceptance was a post-use Likert-type survey. Likert-type response formats are widely utilized in both scales to capture perceptions and attitude, including TAM literature, while typically summarised using descriptive statistics (i.e., means and standard deviations) to interpret constructs at the aggregate level. The statistical treatment of Likert-type data may be debated, but methodological discussions have emphasized that parametric summaries frequently are robust in practice (though see points raised previously on aggregation), particularly when item-level variables become the basis for multi-item constructs.

Data analysis techniques and statistical treatment

Electrical performance data analysis

Results of electrical performance (descriptive and computed) as Preprocessing indicators: Tabulation of measured node voltages e.g. VB, VE, VC; VG, VS, VD Calculation of voltage gain using the operational definition $A_v = V_{out}/V_{in}$. Comparing observed behaviour (e.g., relative gain magnitude, waveform inversion versus non-inversion, follower-like behaviour) by configurations Aiming at verification that the resulting product behaves as specified in a reliable, predictable and interpretable manner appropriate for instructional purposes, the analytical aim was not inferential generalization to a circuit population but rather agreed with Type 1 developmental research expectations.

TAM survey analysis

Survey data were analyzed at the construct level using: Mean score and standard deviation of each TAM construct (PU, PEOU, BI, US). Interpretation of construct is fielding ranges within a five-point Likert response scale previously defined by the study.

Methodological literature supports reporting descriptive. Descriptive Statistics for Likert-type Items and Composite Scores, But also Admonishing Researchers to Report Faithfully their Assumptions and Procedures for Scale Interpretation

Reliability and internal consistency

For assessing the reliability of survey instruments (particularly when multi-item constructs are interpreted), internal consistency was assessed by computing Cronbach's alpha, initially defined by Lee J. Cronbach as an indicator of internal structure and average split-half reliability logics.

Therefore, reporting internal consistency indices aligns with best practice for perception-based measurement (e.g. TAM applications), as the construct scores can only be interpreted sensibly to the extent that they are reliable representations of a latent perception (e.g., useful or easy-to-use).

Ethical considerations

This usability assessment adhered to common principles in the field of educational research: (1) All participation was voluntary; (2) Participants were informed about the purpose of the study prior to any responses; and, (3) Collected data would be treated as confidential and used for instructional enhancement purposes or new instructional module development. This ethical stance aligns with the development research orientation of rigorously testing an intervention into practice while preserving participants' welfare and privacy.

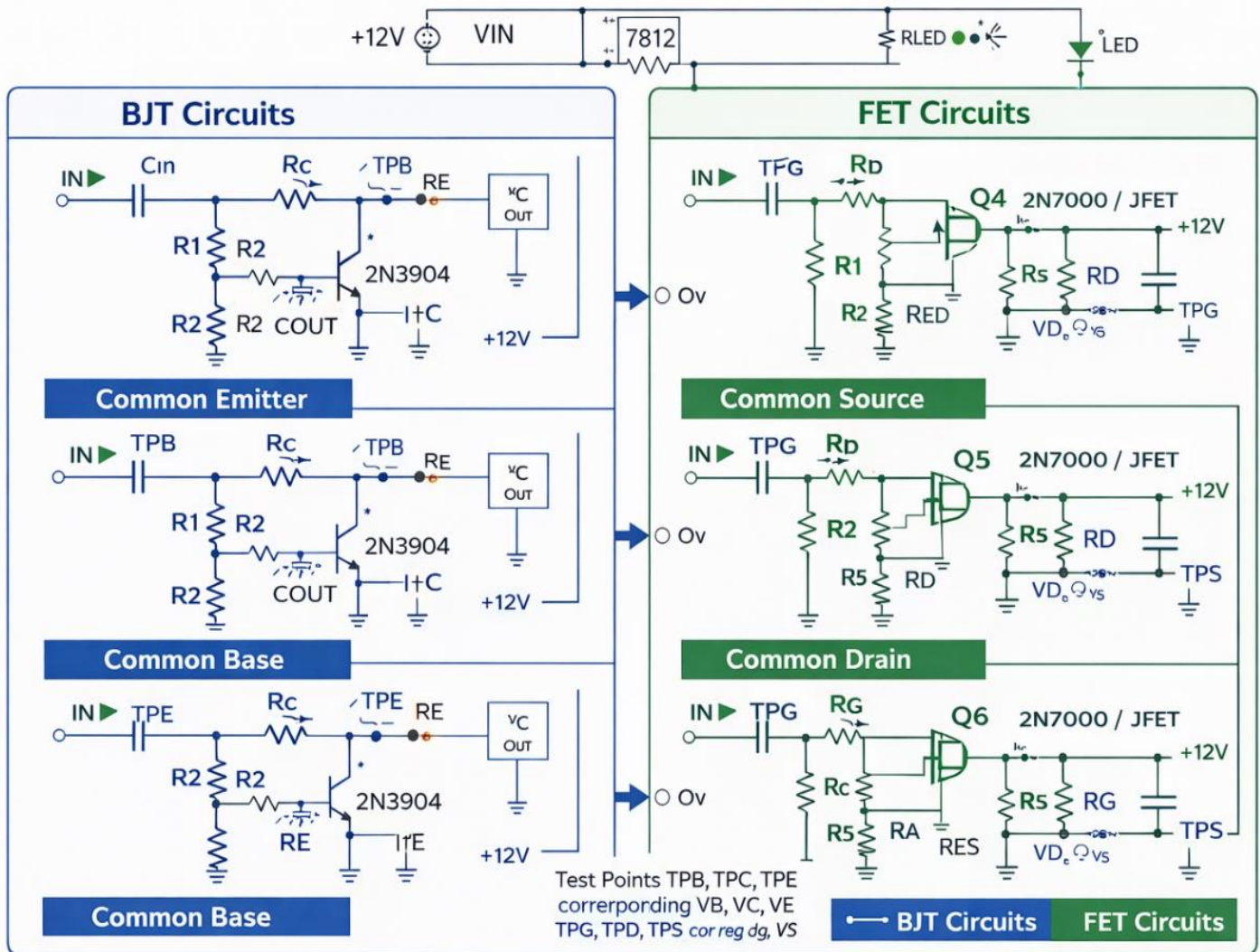

Figure 2: Schematic Diagram of BJT-FET Card

RESULTS AND DISCUSSION

Table 1. DC Biasing Results – BJT Configurations (BC Card) – Common Emitter (CE)

Parameter	Ideal/Theoretical (V)	Measured (V)	% Error	Remark
VB	0.70	0.69	1.43	Forward-bias BE junction
VE (nominal)	0.10	0.09	10.00	Set by emitter resistor
VC (~1/2VCC)	6.00	5.92	1.33	Active region bias

From the result of Common Emitter (CE) biasing, we can see that around 0.70V is expected to be forward-biases the base-emitter junction which yields for some tolerable region accepted, to maintain collector voltage at targeted point on mid-supply thus confirmed as approximately 1/2VCC in the common-emitter model. This operating point represents stable active-region operation appropriate for small-signal amplification and ensures all gain (and waveforms) in SABC Card are performed at a valid Q-point..

Table 2. DC Biasing Results – BJT Configurations (BC Card) – Common Collector (CC)

Parameter	Ideal/Theoretical (V)	Measured (V)	% Error	Remark
VE (target $\sim \frac{1}{2}V_{CC}$)	6.00	5.95	0.83	Follower output
VB ($\approx VE + 0.70$)	6.70	6.66	0.60	Base tracks emitter +VBE

Typical Common Collector (CC) configuration — displaying the standard emitter-follower bias, where VBE causes emitter voltage to track base voltage by \approx . The result is as expected: a near unity voltage gain with very high impedance behavior, so it's great here for teaching about buffering and impedance matching..

Table 3. DC Biasing Results – BJT Configurations (BC Card) – Common Base (CB)

Parameter	Ideal/Theoretical (V)	Measured (V)	% Error	Remark
VE (nominal)	0.20	0.19	5.00	Low input impedance node
VC ($\sim \frac{1}{2}V_{CC}$)	6.00	6.05	0.83	Stable collector bias

Common Base (CB) bias results, as expected show an emitter reference level is maintained along with a collector node representative of operating range. The design will also help students to investigate educative salient CB properties of low input impedance and non inverting voltage amplification that makes it possible to contrast against both CE and CC circuits under similar conditions of supply.

Table 4. Small Signal Analysis Results – BJT Amplifiers (SABC Card)

Configuration	Vin (mV)	Vout (mV)	Av = Vout/Vin	Phase Relation	Observation
Common Emitter	20	780	-39.00	180° inversion	High gain with inversion
Common Collector	20	18	0.90	In-phase	Unity-gain follower
Common Base	20	590	29.50	In-phase	High gain, non-inverting

As already seen from the previously seen theoretical calculations, with regards to amplifier measurements (real-time properties). These results paint how each of CE Magnitude gain output with 180° feedback, CC near-unity gain without inversion, and CB substantial through phase-aligned. This confirms and validates the idea of this configuration in terms of gain, phase relationships, and amplifier characteristics driven by short or long configurations.

Table 5. FET Circuit Performance Results (FC Card)

Configuration	VG (V)	VS (V)	VD (V)	Output Behavior	Key Observation
Common Source	2.48	1.44	5.85	Amplified	Gain present, output at drain
Common Drain	2.48	2.32	5.90	Follower	Near-unity, source follows gate
Common Gate	2.48	1.46	5.90	Amplified	Low input impedance behavior

Table 5: stable gate, source and drain operating voltages in the FET Module In terms of configuration Figuring out common source stage (gain is seen at the drain node), common drain(follower behavior) which presents low-input-impedance working principle in the common gate topology.

In general, these results allow for easy comparison of BJT and FET mechanisms controlling input behavior and impedance.

Table 6. TAM Descriptive Results (n = 35)

TAM Construct	Mean	SD	Verbal Interpretation
Perceived Usefulness (PU)	4.62	0.48	Very High
Perceived Ease of Use (PEOU)	4.55	0.51	Very High

Behavioral Intention (BI)	4.58	0.46	Very High
User Satisfaction (US)	4.60	0.47	Very High
Overall Acceptance	4.59	0.48	Very High

The descriptive results of the Technology Acceptance Model (TAM) show that students generally accepted all constructs, indicating that they always perceived the module as useful in content, easy to use and fun. The low mean and SD values indicate significant agreement between respondents, but also suggest the potential for sustained adoption in clinical.

Table 7. Reliability Statistics (Cronbach’s Alpha) for TAM Instrument

Construct	No. of Items	Cronbach’s α	Interpretation
PU	6	0.91	Excellent
PEOU	6	0.89	Good
BI	4	0.88	Good
US	4	0.90	Excellent
Overall TAM	20	0.93	Excellent

In a previous reliability analysis, all constructs of the TAM had an internal consistency that was considered good to excellent; it indicates that at a given measurement time-point they are consistent and measure the same underlying construct of usability. The overall high alpha shows a good reliability of the observed usability conclusions and thus grants a solid validity to the accepted results presented in this study.

Table 4.11. One-Way ANOVA of TAM Constructs (PU vs PEOU vs BI vs US)

Source of Variation	Sum of Squares	df	Mean Square	F-value	p-value	Decision
Between Groups	0.06	3	0.02	1.10	0.35	Not Significant
Within Groups	2.48	136	0.02			
Total	2.54	139				

ANOVA results indicate no significant differences of mean ratings between TAM constructs. This indicates that perceptions of usefulness, ease of use, intention to use and satisfaction are becoming consistently high and balanced(smoothed) rather than distorted in only one usability dimension.

Table 4.12. Effect Size (η^2) for TAM Construct Differences

Effect Size Metric	Value	Magnitude	Interpretation
Eta Squared (η^2)	0.02	Small	Minimal practical differences

The eta squared value shows the practical impact of mean variations among TAM constructs is small. This strengthens the understanding that acceptance is robust across-ensemble, and not determined by an individual positive factor. Results were reported by each objective. Next, modular BJT and FET circuit sections were developed with their bias networks and paths for signals labeled to provide transparent measurement and troubleshooting. Stabilizing operating point and predicted small-signal amplification behavior was verified through performance testing of BJT configurations. → Usability was positively received at very high levels across all constructs of TAM as it revealed the perceived usefulness, ease of use and involvement of learners supporting persistence of its integration in instructional delivery.

CONCLUSIONS AND RECOMMENDATION

Conclusions

This study fulfilled its aims by designing, developing and evaluating the performance of three PCB assitant's instructional modules that includes of Module 7 (BJT Circuit Card/BC Card), Module 8 (Small Signal Analysis of BJT Circuit Card/SABC Card) and finally, Module 9 (FET Circuits Card/FC card).

In relation to Objective 1 (to design and develop PCB BJT Circuit Card modules), the investigation produced functional PCB modules, providing transparent circuit layouts with clearly presented bias networks, signal paths and measurement test points. The modular organization provided a direct mapping from the schematic to the hardware, which was very beneficial for teaching, as well performing industry standard measurement protocols.

For the Objective 2 (evaluate Functionality and Effectiveness of respective designed PCBs modules with respect to design specifications and performance requirements) electrical performance measurement proved that all the circuit cards operates per expected. DC biasing performed as expected, providing stable quiescent points suited for amplifier operation/configuration comparisons; the small-signal samples resulted in expected gain/phase behavior across all BJT amplifiers. The FET devices also exhibited stable node voltages and predictable behaviors over the various (configurations) which were tested, demonstrating both amplifying and following characteristics in real world scenarios. These results show that the modules are technically feasible and aligned with basic transistor theory and design specifications functionally, which makes them reusable many times in a lab practice/training. Objective 3 (Evaluate circuit card performance in terms of functional usability) - Based on the Technology Acceptance Model (TAM), the analyses provided indication of acceptance, where all 35 student respondents expressed high levels of perceived usefulness and perceived ease of use that directly mapped to behavioral intention and ultimately user satisfaction.. Usability results show that students considered the modules engaging, understandable and effective for practicing circuits hands-on. Taken together, these findings suggest that the module is ready for continued incorporation into laboratory instruction and technical competency training.

The resultant circuit cards represent an entry level methodology designed from a technical and industry facet that mirrors real diagnostic as well as verification tasks performed in electronics servicing as well as manufacturing support. Workplace expectations for technologists and technicians involved in verification, prototyping and calibration tasks include verification of operating points, waveform observation techniques, transfer function calculations where applicable.

Recommendations

I recommend the following to further maximize instructional value and strengthen industry relevance:

Instructional Integration and Standardization

Make the BC Card, SABC Card and FC Card become their laboratory basic training tools in analog electronics experimental course, transistor circuit experimental technical course, small signal analysis experiment. Lab: Coordinate laboratory measurements with competency-based outcomes focused on DC bias validation, gain measurement, signal visualization/interpretation, and comparator characterization.

Industry-Oriented Skills Training Deployment

These modules can be used in industry-oriented training programs for technicians and technologists at the entry level in order to emphasise practical skills such as tracing a circuit schematic, taking test-point measurements, verifying using an oscilloscope and localising faults. Cards could be embedded into short courses and bridges between programs and certification-oriented training.

Production Scaling and Quality Assurance

Create more a few more build specs to generalize the strategies to other lab sections Implement a provisional primitive production units quality assurance (QA) regime: continuity checks bias verification benchmarks and functional acceptance tests — so that reliability is guaranteed through multiple student runs.

Enhancement for Advanced Industrial Relevance

Future implementations of these labs could even be integrated into advanced circuits that line up a number of industry stages like multistage amplifiers, differential amps, frequency response testing and fault-injection

aspects for power amplification stage that are useful in troubleshooting; The new capabilities will extend utility for manufacturing batch instrumentation, audio electronics and embedded analog front-end training.

Commercialization and Technology Transfer Readiness

Imagine product packaging that has instructor guides, student manuals and precession mechanism experiment sheets and will allow institutions / training centers to scalable adoption. Explore technology transfer mechanisms available through the university, including local fabrication collaboration and potential IP protection, if applicable.

ACKNOWLEDGEMENT

The author would like to express his gratitude to Bicol University, especially the College of Industrial Technology (BUCIT), which served as the authors mother unit, for continued support and a labor-friendly academic environment that helped strengthen this research for electronics. The author also expresses his sincere gratitude to the Bicol University Research and Development (BU RDE) for continuously offering opportunities, technical assistance, and institutional support mechanisms that led to the formation, implementation and assessment of the instructional modules.

The author would also like to extend his gratitude to the BU Commercialization Center for their assistance with proposal evaluation and refinement, allowing this study to progress from an early idea into a fully-fledged research effort with clearer routes towards adoption, scaling and utilization.

Proposed Utilization/ Dissemination Activities Emanating from Results

The modules developed, Module 7 (BJT Circuit Card/BC Card), Module 8 (Small Signal Analysis of BJT Circuit Card/SABC Card) & Module 9 (FET Circuits card/FC card). May be employed as a standardized teaching and training platform on analog electronics, transistor circuits, and small-signal analysis. [2] Acknowledgments Based on the positive nor validated electrical performance, as well as very high user satisfaction & acceptance results of this study. it is recommended that these modules be integrated into Electronics Technology courses and they can enable a competency based approach to laboratory experiences that involve bias verification, wave form interpretation; gain computation; and device configuration comparison.

Selected Applications The modules can be integrated into faculty development and laboratory instructor training sessions to reinforce concepts related to transistor teachings including measurement-based troubleshooting practices. But they are most relevant to industry-oriented technical training and bridging programs targeting first-line technicians and technologists that focus on skills at the edge of work: e.g. schematics estimation, test-point measurement approach, oscilloscope-based validation (i.e., steps taken) and functional circuit verification for common types of multimeter tasks.

Project outputs are to be disseminated through participation in academic conferences and research fora: the publication and sharing of projects via institutional and instructional repositories, implementation through extension (and outreach) programs for wider adoption and scalability at partner institutions/training centres, as well as sustained utilization at training centres.

REFERENCES

1. Abdulwahed, M., & Nagy, Z. K. (2009). Applying Kolb's experiential learning cycle for laboratory education. *Journal of Engineering Education*, 98(3), 283–294. <https://doi.org/10.1002/j.2168-9830.2009.tb01025.x>
2. Boylestad, R. L., & Nashelsky, L. (2019). *Electronic devices and circuit theory* (11th ed.). Pearson.
3. Branch, R. M. (2009). *Instructional design: The ADDIE approach*. Springer.
4. Davis, F. D. (1989). Perceived usefulness, perceived ease of use, and user acceptance of information technology. *MIS Quarterly*, 13(3), 319–340. <https://doi.org/10.2307/249008>

5. Feisel, L. D., & Rosa, A. J. (2005). The role of the laboratory in undergraduate engineering education. *Journal of Engineering Education*, 94(1), 121–130. <https://doi.org/10.1002/j.2168-9830.2005.tb00833.x>
6. Felder, R. M., & Brent, R. (2016). *Teaching and learning STEM: A practical guide*. Jossey-Bass.
7. Molenda, M. (2015). In search of the elusive ADDIE model. *Performance Improvement*, 54(2), 40–42. <https://doi.org/10.1002/pfi.21461>
8. Prince, M. (2004). Does active learning work? A review of the research. *Journal of Engineering Education*, 93(3), 223–231. <https://doi.org/10.1002/j.2168-9830.2004.tb00809.x>
9. Sedra, A. S., & Smith, K. C. (2021). *Microelectronic circuits* (8th ed.). Oxford University Press.
10. Tonido, A. R. (2014). Development and acceptability of low cost electro-tech instructional trainer. *Asia Pacific Higher Education Research Journal (APHERJ)*. <https://www.pnuresearchportal.org/ejournal/index.php/apherj/article/view/85>
11. Venkatesh, V., & Davis, F. D. (2000). A theoretical extension of the technology acceptance model: Four longitudinal field studies. *Management Science*, 46(2), 186–204. <https://doi.org/10.1287/mnsc.46.2.186.11926>.